

# Kirchhoff's Laws

## 11.6

In 1845, German physicist Gustav Kirchhoff (**Figure 1**) investigated circuits. He was able to describe two important laws: one law describes the electric potential difference and the other the electric current in circuits. When engineers design circuits, they use Kirchhoff's laws to understand what will happen to the voltage and current when the circuit is in use.

### Kirchhoff's Voltage Law

Recall that electric potential difference can also be referred to as voltage. **Kirchhoff's voltage law (KVL)** is stated as follows:

#### Kirchhoff's Voltage Law

In any complete path in an electric circuit, the total electric potential increase at the source(s) is equal to the total electric potential decrease throughout the rest of the circuit.

Electric potential increases at the source, so there must be an electric potential difference or voltage gain across the source. Similarly, electric potential decreases across the loads in the circuit, so there must be an electric potential difference or voltage drop. The sum of the voltage gains and drops in a complete path in a circuit is zero. The electric potential in a complete path in a circuit remains constant.

A series circuit has only one complete path, so the loads must share the amount of electric potential. The total electric potential across the loads must add up to the electric potential at the source (or sources). If  $V_{\text{series}}$  is the electric potential difference across the source of electrical energy, and the subscripts identify the loads, then

$$V_{\text{series}} = V_1 + V_2 + V_3 + \dots$$

A parallel circuit has more than one complete path, so the electric potential decrease across each load must be the same as the electric potential increase at the source (or sources). Thus, the electric potential difference across the loads and source must be the same. If  $V_{\text{parallel}}$  is the electric potential difference across the source of electrical energy, and the subscripts identify the loads, then

$$V_{\text{parallel}} = V_1 = V_2 = V_3 = \dots$$

### Kirchhoff's Current Law

Junctions are points at which you can travel in more than one direction. In electric circuits, junctions are points where the current can split to follow more than one path. **Kirchhoff's current law (KCL)** is stated as follows:

#### Kirchhoff's Current Law

In a closed circuit, the amount of current entering a junction is equal to the amount of current exiting a junction.

A series circuit has only one path, so there can be only one possible current. If  $I_{\text{series}}$  is the current going through the source of electrical energy, and the subscripts identify the loads, then

$$I_{\text{series}} = I_1 = I_2 = I_3 = \dots$$

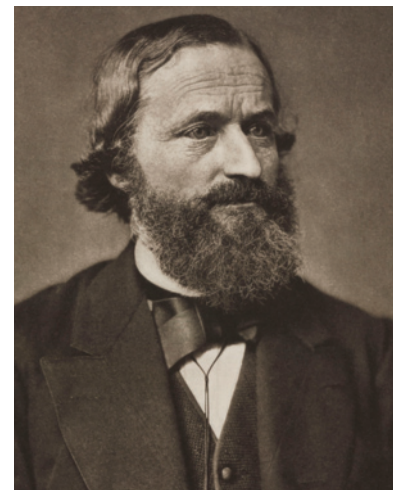

**Figure 1** Gustav Kirchhoff developed laws that describe voltage and current in circuits.

**Kirchhoff's voltage law (KVL)** in any complete path in an electric circuit, the total electric potential increase at the source(s) is equal to the total electric potential decrease throughout the rest of the circuit

**Kirchhoff's current law (KCL)** in a closed circuit, the amount of current entering a junction is equal to the amount of current exiting a junction

#### LEARNING TIP

##### Remembering KVL and KCL

For a series circuit, voltages add up and currents remain constant. For a parallel circuit, voltages remain constant and currents add up.

A parallel circuit has more than one complete path, so the current can split, depending on the number of paths. The more complete paths there are, the more ways the current can be divided among the paths. If  $I_{\text{parallel}}$  represents the current going through the source of electrical energy, and the subscripts identify the loads, then

$$I_{\text{parallel}} = I_1 + I_2 + I_3 + \dots$$

**Table 1** Circuit Symbols

Part of circuit	Circuit symbol
battery	
variable DC power supply	
connecting wire	
resistor	
lamp	
motor	
open switch	
closed switch	

## Applying Kirchhoff's Laws

It is critical to understand the properties of circuits so that they operate as intended. Whether controlling a power plant or designing a circuit, we can use Kirchhoff's laws to analyze circuits to find unknown voltages and currents. To review circuit diagram symbols, see **Table 1**.

### Series Circuits

Assume that the loads are all identical. If three identical light bulbs are connected in series (**Figure 2**), the voltage is divided equally among the three light bulbs. For example, if a 6.0 V battery is connected to three identical light bulbs in series, each light bulb has a voltage of 2.0 V:

$$V_{\text{series}} = V_1 + V_2 + V_3$$

or

$$6.0 \text{ V} = 2.0 \text{ V} + 2.0 \text{ V} + 2.0 \text{ V}$$

The amount of current going into a junction is equal to the amount of current going out of the junction. There is no junction in a series circuit; there is only one complete path. So if the battery has a current of 0.20 A, all the loads also have a current of 0.20 A.

### Parallel Circuits

Again assume that the loads are all identical. When three identical light bulbs are connected in parallel (**Figure 3**), then the voltage is the same for all three light bulbs. For example, if a 6.0 V battery is connected to three light bulbs in parallel, each light bulb has a voltage of 6.0 V.

The amount of current going into a junction is equal to the amount of current going out of the junction. The three light bulbs connected in parallel are in three independent paths. If the battery has 0.30 A of current, the current is divided equally along each of the three paths to each light bulb:

$$I_{\text{parallel}} = I_1 + I_2 + I_3$$

or

$$0.30 \text{ A} = 0.10 \text{ A} + 0.10 \text{ A} + 0.10 \text{ A}$$

In the following Tutorial, you will learn how to solve problems involving mixed circuits that contain both series and parallel connections.

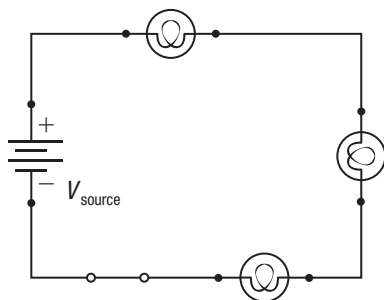

**Figure 2** Series circuit

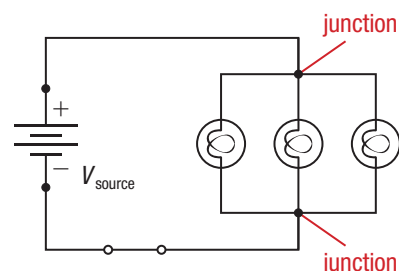

**Figure 3** Parallel circuit

## Tutorial 1 Applying Kirchhoff's Laws

Although we sometimes assume that all the loads in a circuit are identical, in the real world this is usually not the case. Circuits are rarely all series or all parallel; they have a mixture of connections. The following Tutorial shows you how to analyze mixed circuits with various loads.

### CASE 1: APPLYING KIRCHHOFF'S VOLTAGE LAW TO A MIXED CIRCUIT

To analyze a mixed circuit, start by separating the circuit into sections that are connected in parallel and sections that are connected in series. Consider the circuit in **Figure 4** and note the parts labelled “series connection” and “parallel connection.” **Figure 5** shows how to view the circuit as two complete paths. Suppose the voltages at the source, lamp 1, and lamp 3 are 40 V, 10 V, and 20 V, respectively. Find the voltages at lamp 2 and lamp 4.

Using this approach of two separate paths, you can think of two completely independent series circuits.

Using KVL for a series circuit, you can solve for  $V_2$ :

$$\begin{aligned} V_{\text{source}} &= V_1 + V_2 + V_3 \\ 40 \text{ V} &= 10 \text{ V} + V_2 + 20 \text{ V} \\ 40 \text{ V} &= 30 \text{ V} + V_2 \\ V_2 &= 10 \text{ V} \end{aligned}$$

If you apply the same thinking to the other path, you can solve for  $V_4$ :

$$\begin{aligned} V_{\text{source}} &= V_1 + V_2 + V_4 \\ 40 \text{ V} &= 10 \text{ V} + 10 \text{ V} + V_4 \\ 40 \text{ V} &= 20 \text{ V} + V_4 \\ V_4 &= 20 \text{ V} \end{aligned}$$

According to KVL, in a parallel circuit, the voltages are the same. Both  $V_3$  and  $V_4$  are equal to 20 V, as expected, because the potential difference across loads in parallel is always equal.

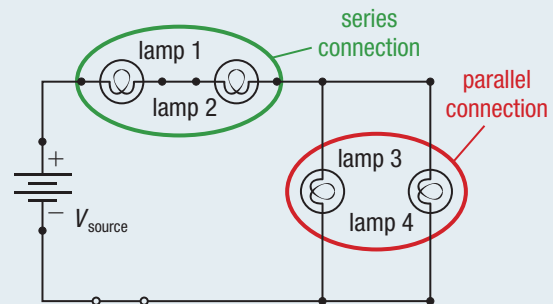

**Figure 4** You can look at this circuit as two complete circuits.

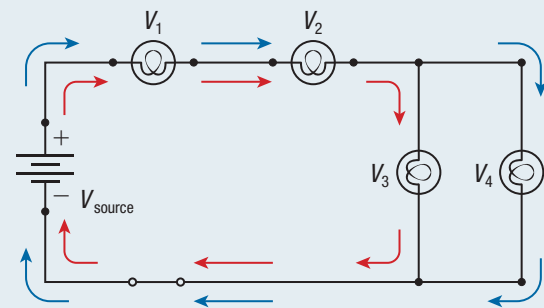

**Figure 5** The red path from the source to lamp 1, lamp 2, lamp 3, and back to the source is one path. The blue path from the source to lamp 1, lamp 2, lamp 4, and back to the source is another path.

### CASE 2: APPLYING KIRCHHOFF'S CURRENT LAW TO A MIXED CIRCUIT

Using the same circuit, you can use KCL to determine the current. The current in a series circuit is constant and the same as the source current. The current in a parallel circuit is divided along the paths. Suppose you are given the following information:  $I_{\text{source}} = 0.40 \text{ A}$  and  $I_3 = 0.10 \text{ A}$ . Using these values and KCL, you can find  $I_1$  and  $I_2$ .

$$\begin{aligned} I_{\text{series}} &= I_1 = I_2 \\ 0.40 \text{ A} &= I_1 = I_2 \end{aligned}$$

Therefore,  $I_1 = 0.40 \text{ A}$  and  $I_2 = 0.40 \text{ A}$ .

The amount of current entering a junction is equal to the amount of current exiting the junction. You can write this as

$$\begin{aligned} I_{\text{parallel}} &= I_3 + I_4 \\ 0.40 \text{ A} &= 0.10 \text{ A} + I_4 \\ I_4 &= 0.30 \text{ A} \end{aligned}$$

So  $I_4$  is equal to 0.30 A (**Figure 6**).

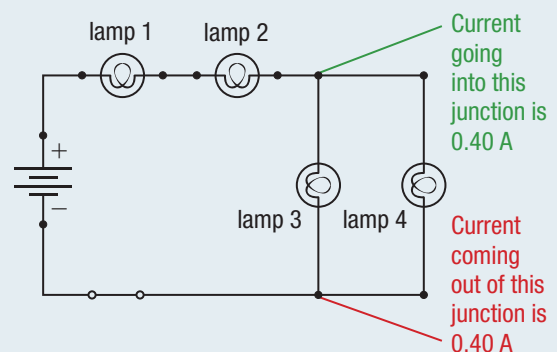

**Figure 6** The current entering a junction equals the current exiting the junction.

## Practice

- For the circuit in **Figure 7**,  $V_{\text{source}} = 60.0 \text{ V}$ ,  $V_1 = 20.0 \text{ V}$ , and  $V_3 = 15 \text{ V}$ . Determine  $V_2$ ,  $V_4$ , and  $V_5$ . **T/I** [ans:  $V_2 = 25 \text{ V}$ ;  $V_4 = 15 \text{ V}$ ;  $V_5 = 15 \text{ V}$ ]
- For the circuit in Figure 7,  $I_1 = 0.70 \text{ A}$ ,  $I_3 = 0.10 \text{ A}$ , and  $I_5 = 0.20 \text{ A}$ . Determine  $I_{\text{source}}$ ,  $I_2$ , and  $I_4$ . **T/I** [ans:  $I_{\text{source}} = 0.70 \text{ A}$ ;  $I_2 = 0.70 \text{ A}$ ;  $I_4 = 0.40 \text{ A}$ ]

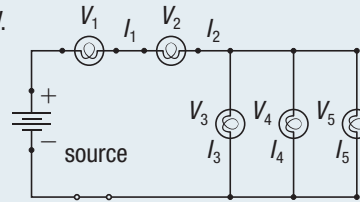

Figure 7

## 11.6 Summary

- Kirchhoff's voltage law (KVL) states that the voltage gains are equal to the voltage drops in a complete path in a circuit.
- Kirchhoff's current law (KCL) states that the current entering a junction is equal to the current exiting a junction in a circuit.
- The equations for Kirchhoff's laws are

$$V_{\text{series}} = V_1 + V_2 + V_3 + \dots \quad V_{\text{parallel}} = V_1 = V_2 = V_3 = \dots$$

$$I_{\text{series}} = I_1 = I_2 = I_3 = \dots \quad I_{\text{parallel}} = I_1 + I_2 + I_3 + \dots$$

## 11.6 Questions

- What is wrong with the following information? State whether you are applying KCL or KVL in your answer. **K/U C**
  - The current going into a parallel circuit is listed as 0.50 A and the current coming out of the parallel circuit is listed as 0.30 A.
  - A student measures the voltage across each of the three loads in a series circuit to be 10 V each. The voltage across the source is measured to be 10 V.
  - For a circuit with two lamps connected in parallel, a student measures the voltage drop across one lamp to be 20 V. The student measures the voltage drop across the second lamp to be 10 V.
  - A student is using an ammeter and notes that it reads 0.15 A on the first lamp, 0.20 A on the second lamp, and 0.25 A on the third lamp. The student says the lamps are connected in series.
- For each of the following circuits, the given values are listed in a table. Copy each table into your notebook and find the missing values. **T/I C**

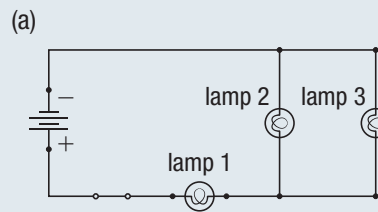

Item	V (V)	I (A)
source		
lamp 1	2.0	3.0
lamp 2	1.0	1.5
lamp 3		

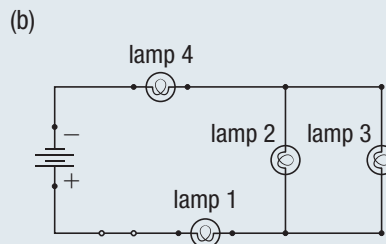

Item	V (V)	I (A)
source	24.0	2.0
lamp 1	10.0	
lamp 2	6.0	1.0
lamp 3		
lamp 4		

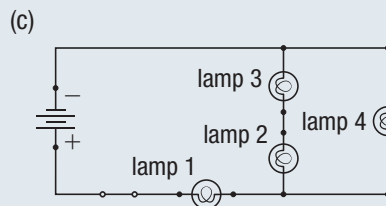

Item	V (V)	I (A)
source	6.0	4.0
lamp 1		
lamp 2	1.0	2.0
lamp 3	2.0	
lamp 4		